

## Stainless steel air cylinders are now being incorporated into the in-cab air release option

*Same form, fit, function and quality.*

Recent events have created numerous challenges in the Class 8 supply chain. At Fontaine Fifth Wheel, our team has worked with due diligence to ensure that our products are readily available for OEM production and the aftermarket. To do this, our engineering and production teams are developing options to alleviate any potential bottlenecks.

Our customers will now see a stainless-steel air cylinder being used on our in-cab air release system versus a composite cylinder. Fit, form, function or quality will not change or be affected from this change. The only difference will be look.



**Composite cylinder for in-cab air actuated models**



**Stainless steel cylinder for in-cab air actuated models**

## Installation Instructions

### Air Actuated Fifth Wheel Cylinder Kit For The No Slack® Fifth Wheel (KIT-AA-6000L)

	Parts provided in this kit	QTY
①	Left Hand Air Cylinder	1
②	Air Actuated Spring	2
③	Clevis Pin 1/2" x 1"	2
④	Flat Washer 1/2"	2
⑤	Cotter Pin 5/32"	2
⑥	Quick Disconnect Valve	1

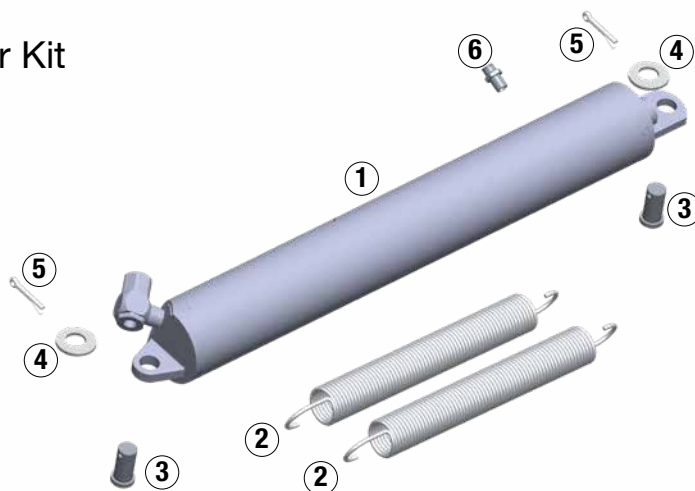

Installation Instructions (read entire directions and look at all illustrations before beginning):

1. Remove fifth wheel from mounting brackets (Cleaning the fifth wheel before installing the kit is recommended).
2. Place the fifth wheel in the upside down position (Make sure that the fifth wheel is placed on a suitable work surface).
3. Remove the old bumper spring and pull handle spring from the fifth wheel (Please review bottom image of Diagram 1 for more information).
4. Install the new air cylinder
  - IMPORTANT:**
    - Orient cylinder, washers and pins as shown in top of Diagram 1.
    - Air cylinder positioning is critical. See Diagram 1 and Diagram 2 on following page.
5. Install the air actuated springs for bumper latch and pull handle (Bottom of Diagram 1).
6. Reinstall the fifth wheel back on the mounting brackets.
7. Insert the airline supply into the quick disconnect on the exhaust valve.
8. Open and close the fifth wheel using the air cylinder to ensure proper function.
9. Tilt the fifth wheel forward to ensure that the cylinder and/or air supply line does not interfere with another component (Important: See Diagram 3).

### Diagram 1

ISO/TS16949 REGISTERED  
TB-004 • November 2022 R10

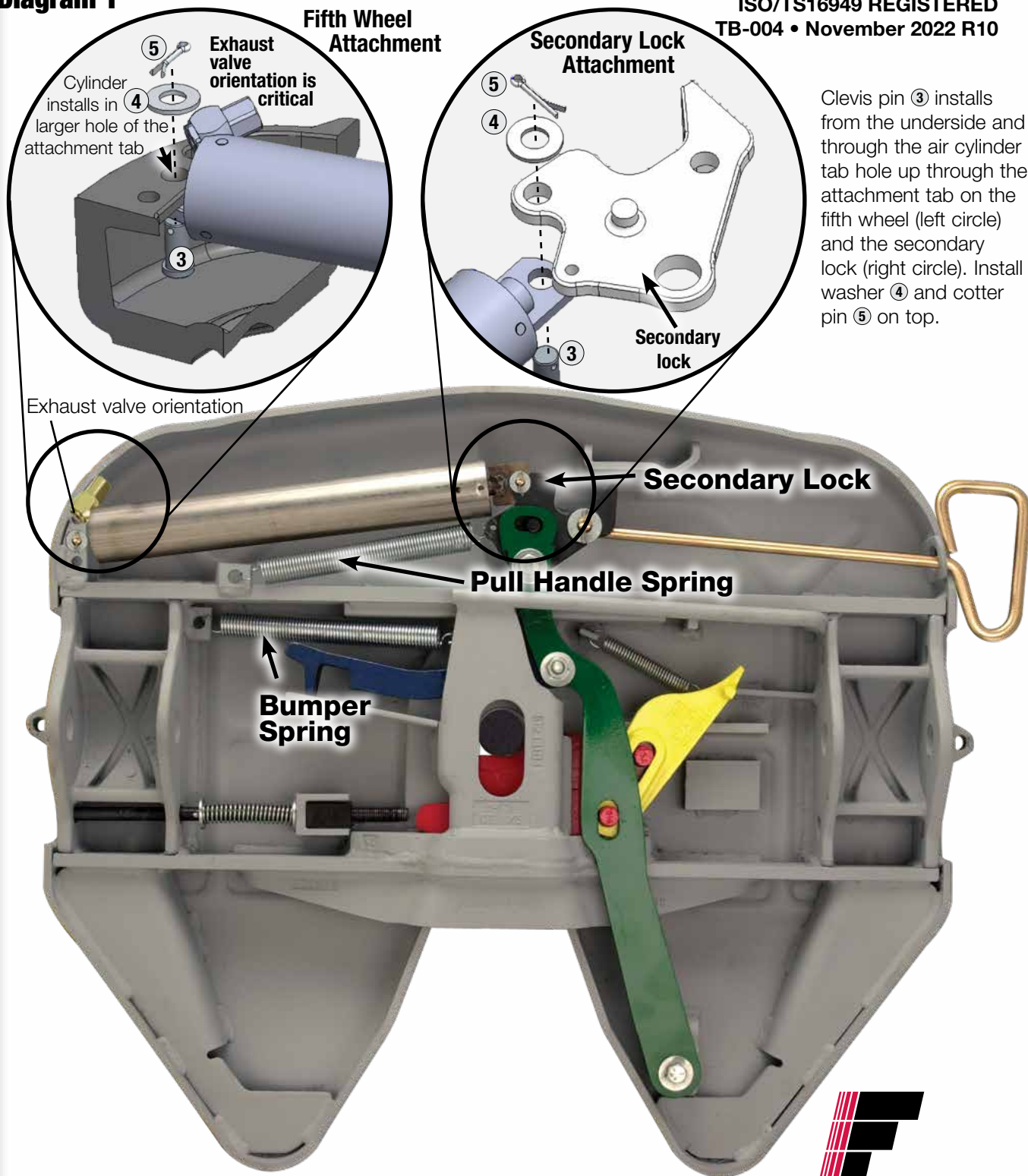

Clevis pin ③ installs from the underside and through the air cylinder tab hole up through the attachment tab on the fifth wheel (left circle) and the secondary lock (right circle). Install washer ④ and cotter pin ⑤ on top.

### Diagram 2

ISO/TS16949 REGISTERED  
TB-004 • November 2022 R10

### Exhaust Valve Orientation is Critical

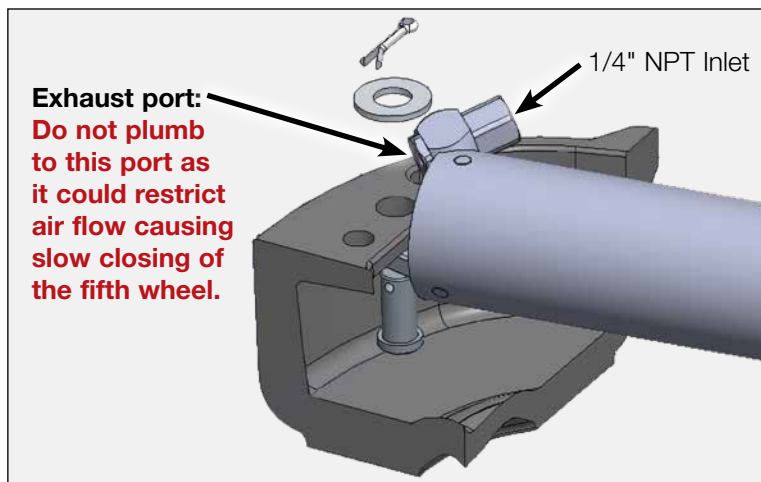

For replacing a damaged exhaust valve see TB-075 at [fifthwheel.com](http://fifthwheel.com)

### Diagram 3

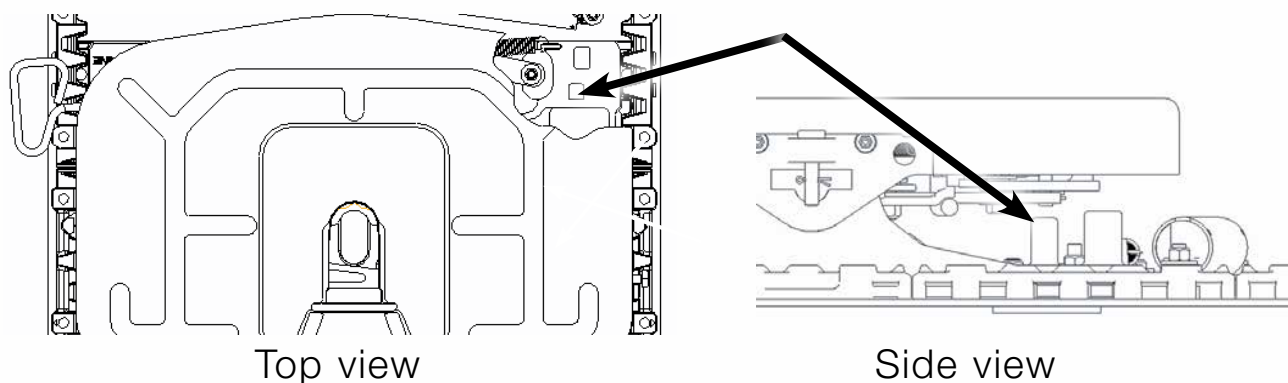

**IMPORTANT:** If applicable, remove indicated front rocker limit block to prevent air cylinder damage.

